

Engineering Journal

Volume Four

IN-DEPTH ARTICLES	A layman's overview of 1-Wire technology and its use	3
	Telecom template measurement and compliance	9
DESIGN SHOWCASE	Reducing error in bandgap-based temperature sensors with curve fitting	14
	Using spread-spectrum oscillators to reduce radiated emissions in consumer products	16

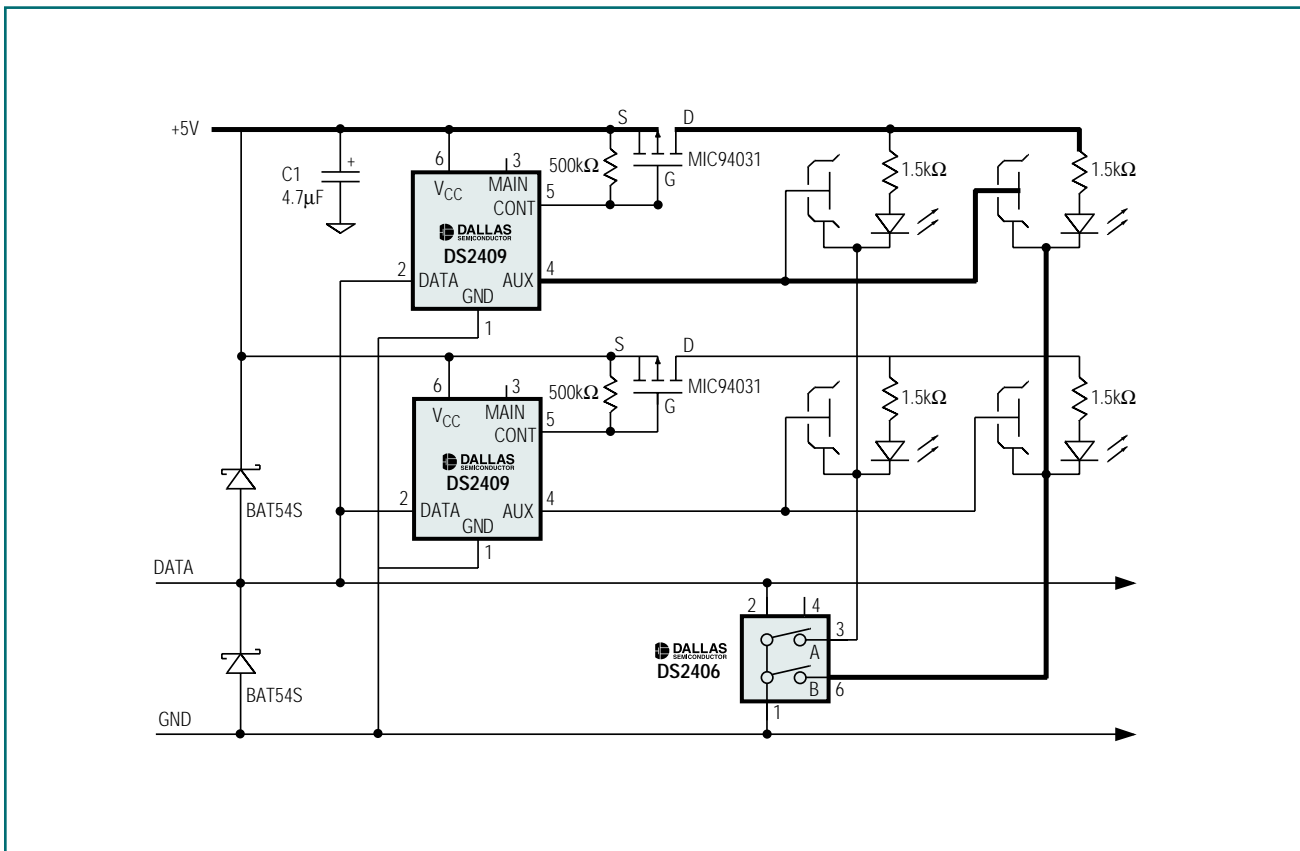

A distinct advantage of 1-Wire instruments is they all communicate using 1-Wire protocol regardless of the particular property being measured.

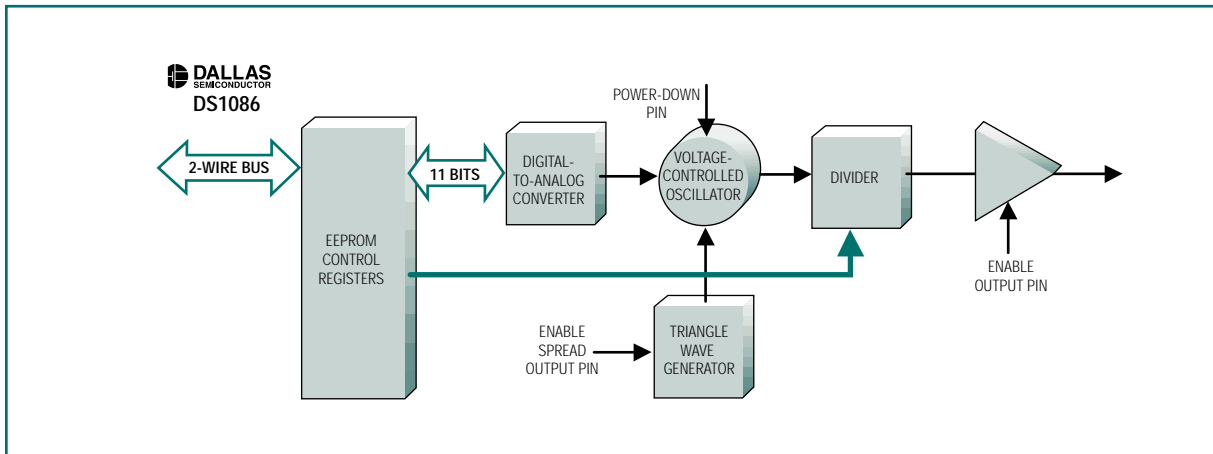

Figure 5. The DS1086 uses the oscillator found in other EconOscillators along with a triangle-wave signal that is applied to the voltage-controlled oscillator, thus dithering the output.

designer to use shielding, EMI filtering, and careful circuit layout to reduce radiated emissions. By adding FM modulation or dithering to the frequency of a system's clock, radiated emissions can be spread over a narrow spectrum, reducing the peak-radiated emissions at any one frequency. This simplifies the designer's engineering task and can reduce the cost of the manufactured product. In

the past few years, the use of spread-spectrum clock oscillators gained popularity. The characteristics of the clock are a relatively precise short-term stability of frequency, usually on the order of 200ppm to 300ppm. The long-term frequency stability is swept over frequency values ranging from 1/2% to 4% of the oscillator's center frequency.

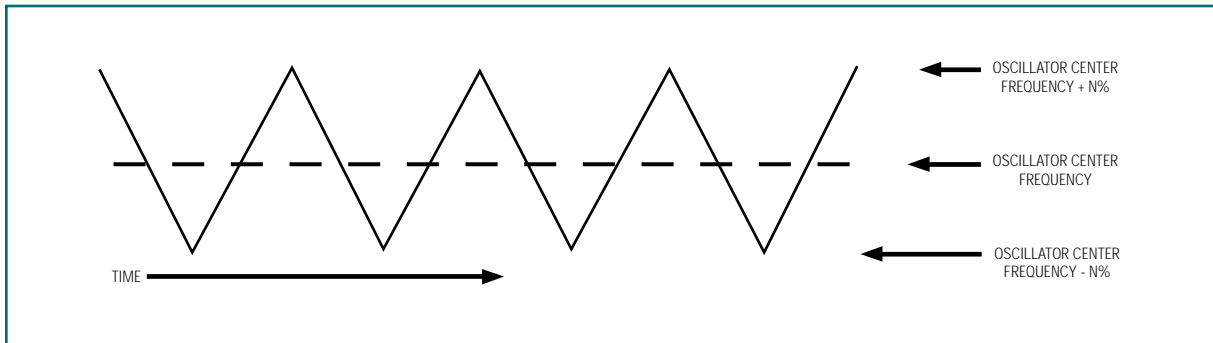

Figure 3. The signal's frequency is selected so that it is much lower than the oscillator it is dithering. Consequently, electronics driven by the oscillator are not affected by rapid frequency changes.

oscillator shown earlier. The graph also shows DS1086 with both a 0% dithered output and a 4% dithered output. The graph demonstrates how the “spreading” of an oscillator’s frequency reduces the peak radiated emissions at any particular frequency to below the FCC-mandated levels.

The DS1086

The DS1086 is an EconOscillator™ designed to induce dither in the oscillator output, reducing radiated emissions

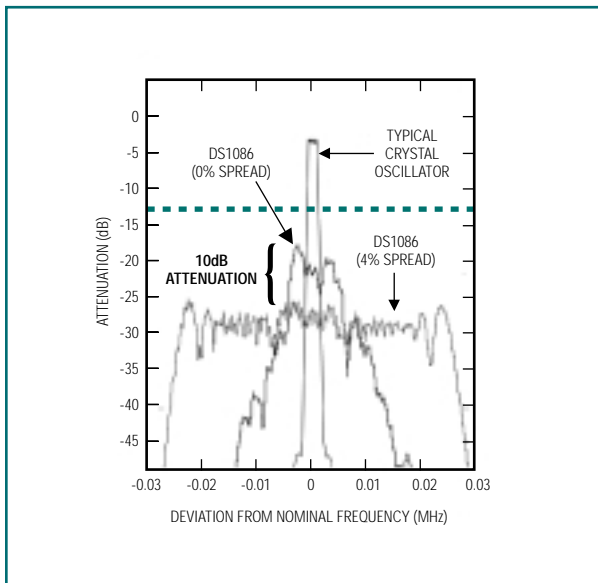

Figure 4. Radiated emission reduction using spread-spectrum techniques. The radiated emissions of the zero-dither DS1086 and other EconOscillators such as the DS1073, DS1075, and DS1077 are less than that of the crystal oscillator due to the inherent dithering characteristics of an all-silicon oscillator.

EconOscillator is a trademark of Dallas Semiconductor.

in systems from printers to gaming consoles. The device consists of a programmable 66MHz to 133MHz clock-frequency generator tunable in 5k increments through a 2-wire interface. This, in conjunction with a 5-bit divider chain, provides for a broad selection of frequencies ranging from 258kHz to 133MHz. Input pins provide control for gating the clock output, turning on and off the dither, and disabling the master. Three dither options are selectable: 0%, 2%, and 4%. Unlike low-EMI oscillators from other manufacturers, the DS1086 requires no external crystal or clock reference for operation, making it the smallest footprint, low-EMI clock available (Figure 5). It is available in an 8-pin SO package.

Like other EconOscillators, the DS1086 uses a precisely controlled digital-to-analog converter (DAC) in conjunction with a calibrated voltage-controlled oscillator (VCO) to generate its center-frequency output. Frequency dithering is injected into the output frequency by summing a triangle-wave voltage signal into the VCO input. The triangle wave’s amplitude determines the percentage dither in the output clock. This can be set at 0%, 2%, or 4%, depending on the application. Note that the 0% dither selection has approximately 1% dither that is intrinsic to the architecture of all EconOscillators. Even standard EconOscillators with this characteristic have up to a 10dBm reduction in radiated spectrum when compared to a crystal oscillator, without any additional circuitry.

Summary

FCC radiated emission compliance standards for consumer electronics made design efforts increasingly difficult for the circuit designer. Higher clock speeds include higher harmonic frequencies that force the

A layman's overview of 1-Wire technology and its use

Dallas Semiconductor designs and develops technology based on a single bus master that transmits digital communications and operating power for multiple slaves over a single twisted-pair cable. An important aspect of this technology is that every slave has a globally unique digital address. This technology is called 1-Wire®, because it uses a single wire (plus ground) to accomplish both communication and power transmission. This article briefly discusses the protocol and introduces a variety of applications.

What is the 1-Wire net?

The 1-Wire net is a low-cost bus based on a PC or micro-controller communicating digitally over twisted-pair cable with 1-Wire components. The network is defined with an open-drain (wired-AND) master/slave multidrop architecture that uses a resistor pull-up to a nominal 5V supply at the master. A 1-Wire net-based system consists of three main elements: 1) a bus master with controlling software such as the TMEX™ iButton® viewer; 2) wiring and associated connectors; and 3) 1-Wire devices. The system permits tight control because no node is authorized to speak unless requested by the master, and no communication is allowed between slaves except through the master.

The 1-Wire protocol uses conventional CMOS/TTL logic levels with operation specified over a supply voltage range of 2.8V to 6V. Both master and slaves are configured as transceivers permitting bit sequential data to flow in either direction, but only one direction at a time, with data read and written least significant bit (LSB) first. An economical DS9097U COM port adapter interfaces the RS-232 to the net. A DS2480 serial 1-Wire line driver chip is also available to generate the proper signals and programmable waveforms that maximize performance.

Data on the 1-Wire net is transferred by time slots. For example, to write a logic one to a slave, the master pulls the bus low for 15µs or less. To write a logic zero, the master pulls the bus low for at least 60µs to provide timing margin for worst-case conditions. A system clock is not

required, as each 1-Wire part is self-clocked by its own internal oscillator synchronized to the falling edge of the master. Power for chip operation is derived from the bus during idle communication periods when the DATA line is at 5V by including a half-wave rectifier on each slave.

Whenever the data line is pulled high, the diode in the half-wave rectifier turns on and charges an on-chip capacitor. When the voltage on the net drops below the voltage on the capacitor, the diode is reverse biased, which isolates the charge. The resulting charge provides the energy source to power the slave during the intervals when the net is pulled low. The amount of charge lost during these periods is replenished when the data line returns high. This concept of “stealing” power from the net by a half-wave rectifier is referred to as “parasite power.”

When communicating, the master resets the network by holding the bus low for at least 480µs, releasing it, and then looking for a responding presence pulse from a slave connected to the line. If a presence pulse is detected, it then accesses the slave by calling its address, controlling the information transfer by generating time slots and examining the response from the slave. Once this handshake is successful, the master issues necessary device-specific commands and performs any needed data transfers between it and the slave. The master can select a single slave from many on the net because of its unique digital address.

A unique address for every part

Within each 1-Wire slave is stored a lasered ROM section with its own guaranteed unique, 64-bit serial number that acts as its node address. This globally unique address is composed of eight bytes divided into three main sections. Starting with the LSB, the first byte stores the 8-bit family codes that identify the device type. The next six bytes store a customizable 48-bit individual address. The last byte, the most significant byte (MSB), contains a cyclic redundancy check (CRC) with a value based on the data contained in the first seven bytes. This allows the master to determine if an address was read without error. With a 2⁴⁸ serial number pool, conflicting or duplicate node addresses on the net are never a problem.

Because 1-Wire devices can be formatted with a file directory like a floppy disk, files can be randomly accessed and changed without disturbing other records. Information is read or written when the master addresses a device connected to the bus, or an iButton is touched to a probe somewhere along the 1-Wire net. The inclusion of up to

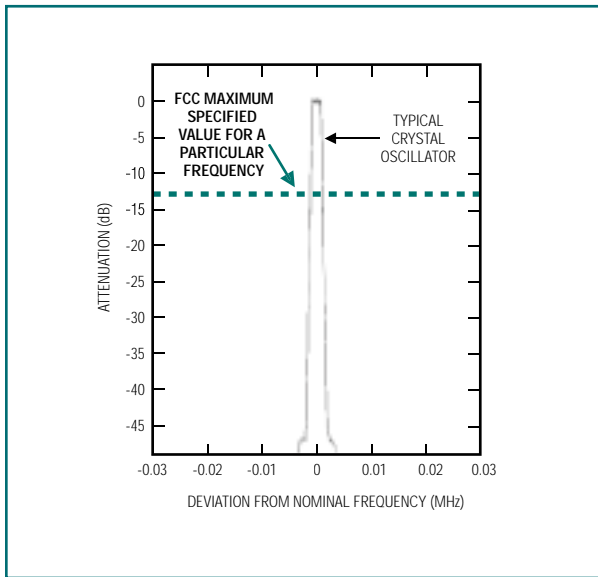

Figure 2. Radiation from crystal oscillator-based consumer products can exceed FCC-mandated limits unless peak-radiated emissions are reduced.

tronic device can radiate, only the amount of energy that may be radiated at any one frequency.

A traditional, older method of reducing radiated emissions involved containment. A personal computer used its grounded steel cabinet as a shield to intercept and dissipate the energy radiated by the motherboard. Plastic cabinets used in enclosed electronic devices were often coated with a metallic layer and grounded to achieve the same purpose. As electronics proliferated and became increasingly smaller, containment techniques became more difficult to accomplish. Higher clock speeds of electronics included higher harmonic frequencies that forced the designer to use shielding, such as EMI filtering, and careful circuit layout to reduce radiated emissions. This approach became costly and more difficult as consumer electronics shrunk. A new method was needed to reduce these peak-radiated emissions.

By spreading or dithering the frequency of a system's clock, radiated emissions can be "smeared" over a narrow spectrum, reducing the peak-radiated emissions at any one frequency. This simplifies the design engineer's task and reduces the cost of the manufactured product. Over the past few years, this use of spread-spectrum clock oscillators to reduce peak-radiated emissions gained popularity in everything from PC motherboards to printers.

History of spread spectrum

During WWII, the U.S. Navy was having problems with radio-controlled torpedoes that were being "jammed" by high-strength RF signals tuned to the same frequency as the transmitting radio. This is an example of radiated susceptibility. In August 11, 1942, Hedy Keisler Markey and George Antheil were granted U.S. Patent Number 2,292,387 for a "Secret Communication System" that solved this problem. The device used a mechanism to rapidly switch between frequencies on the transmitter (this technique is now called frequency hopping). A similar device on the receiver in the torpedo switched between the same frequencies and captured the transmitted signal. The signal controlling the torpedo never remained at any individual frequency long enough to be jammed by an external RF signal at a single frequency. A more sophisticated version of this technique was used half a century later to reduce interference in communication devices such as cellular and cordless phones.

Using spread-spectrum technology to reduce radiated emissions

While the term spread spectrum is used in techniques for reducing radiated emissions in consumer electronics, the application is different than that used in devices such as cordless phones. In the cordless phone (or remote-controlled torpedo) the operating frequency of both the transmitter and receiver are swept over a band of frequencies in unison, reducing radiated susceptibility at any one frequency.

The use of spread-spectrum technology for RF reduction in unintentional transmitters in consumer products such as PCs, involves sweeping the clock that drives the PC over a band of frequencies. Thus, any radiated emissions are spread over the band, and only a small amount of the total energy is radiated at any one frequency. This reduces the peak energy at that frequency to below the FCC mandated levels.

The above method applies a signal to the oscillator that moves the frequency as a function of the signal level. In its simplest form, a triangle signal is applied to the oscillator, which varies the oscillator's frequency as a function of the triangle amplitude (**Figure 3**). Actually, the shape of the signal applied can vary slightly from this triangle example.

Figure 4 is the radiated emission output of a dithered DS1086 oscillator compared to that of the crystal

DESIGN SHOWCASE

Using spread-spectrum oscillators to reduce radiated emissions in consumer products

In 1975 the Federal Communications Commission (FCC), the government agency that regulates radio frequency (RF) emissions in the United States, enacted new regulations called FCC Part 15. These were not directed at controlling equipment such as radio and TV transmitters, or aircraft-navigation and emergency beacons that deliberately radiate high-power RF energy. Instead, these regulations sought to control equipment that did not deliberately radiate RF energy such as televisions, automobiles, and low-power, unregulated RF radiators such as walkie-talkies and electronic remote controls.

A good example of the impetus behind these regulations occurred years ago at Dallas/Fort Worth Airport. Pilots, during takeoffs and landings, reported loss-of-control situations with recently developed electronic flight-control systems. The FCC traced the cause to interference from remote-controlled garage-door openers in homes in the surrounding suburban areas. The Part 15 regulations addressed this problem by requiring that all electronic equipment sold in the U.S. be tested and certified to ensure against radiated RF energy that could cause malfunctions in other electronic devices.

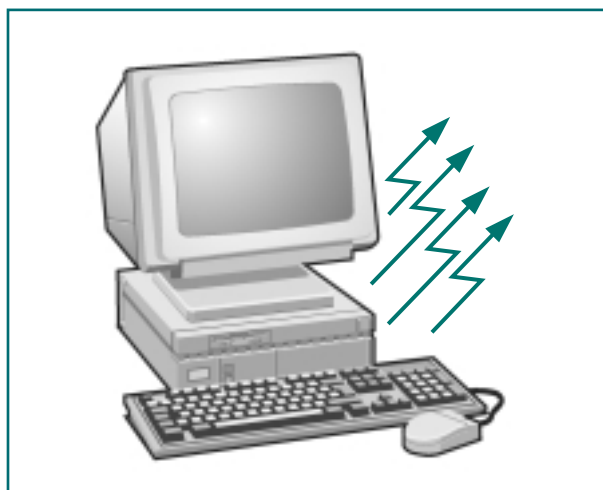

Figure 1. Consumer electronics radiate unintentional RF energies.

During the 1980s and 1990s, electronic devices from microwaves to cell phones proliferated. Cross interference between these devices became a problem. Microwave ovens interfered with pacemakers, while cable modems interfered with cordless phones. Similarly, computer monitors radiated enough RF energy that interfered with most other electronic equipment in their vicinity.

The FCC and other regulatory bodies such as the Electro Magnetic Compatability (EMC) agency in Europe, responded with tighter regulations regarding these emissions in all electronics. In the U.S., FCC Part 68 regulated industrial and commercial electronic devices. Part 68, Class A involved equipment used in an industrial environment while Part 68, Class B addressed consumer products. This article will concentrate on Class B electronics only.

What are radiated emissions in consumer products?

Any piece of electronics that has a changing electrical signal radiates emissions. In the case of the PC motherboard with a clock running at a certain frequency, it will radiate RF energy tightly centered on the frequency of the master oscillator.

Definitions:

- *Radiated susceptibility* is the sensitivity of a piece of electronic equipment to interference from outside RF energy sources.
- *Radiated emissions* are RF energies unintentionally radiated by a piece of electrical equipment, such as a PC or monitor, which might have some impact on another piece of electrical equipment (**Figure 1**).

If the radiated RF energy from a PC motherboard is measured, radiation spikes at the oscillator's center frequency are present (**Figure 2**). FCC requirements for consumer products (FCC Part 68, Class B) require that radiated emissions must be below a specified maximum value. Ironically, it does not limit the total energy an elec-

intersection and turns it on. If desired, the DS2409 can be switched repeatedly between main and AUX outputs causing the LED to blink for greater visual effect. If the main outputs of all DS2409s are turned on, the LEDs in the entire column of the selected DS2406 turn on. Alternately, if the outputs of all DS2406s are turned on, the LEDs in the entire row of the selected DS2409 turn on. Consequently, turning on all column and row switches illuminates the entire array, which serves as a convenient test to verify that the system is fully functional. While a DS9092 iButton probe is shown in the example, solder-mount 1-Wire devices could be used as well.

Addressable digital instruments

In addition to the DS2406 and DS2409 1-Wire control chips, several digital functions such as temperature sensors and analog-to-digital converters (ADCs) are available. These ICs measure a wide variety of physical properties over the 1-Wire net. A distinct advantage of 1-Wire instruments is that all communicate using 1-Wire protocol regardless of the particular property (for example, voltage, current, and resistance) being measured. Other methods employ a variety of signal-conditioning circuitry such as instrumentation amplifiers and voltage-to-frequency converters, which out of necessity makes their outputs different and often requires separate cables for each sensor.

The unique ID address of each device is the key for the bus master to interpret what parameter a particular 1-Wire instrument is measuring. Several examples of 1-Wire instrumentation for environmental measurement are presented later in this article. Note that all circuit examples use a BAT54S dual Schottky diode and input capacitor to provide a local source of power. The remaining Schottky diode in the package is connected across DATA and GND and provides circuit protection by restricting signal excursions that go below ground to approximately -0.4V. Without this diode, negative signal excursions on the bus in excess of 0.6V forward bias the parasitic substrate diode and interfere with chip function.

Our first example uses the DS2423 counter, which has inputs that respond to logic-level changes or switch closures. This makes it suitable to implement a variety of tally or rate sensors. A circuit example using magnetically actuated reed switches is shown in **Figure 2**. In the circuit, an external 1M Ω pull-down resistor is used from the inputs to ground to prevent generating spurious counts during turn-on and to minimize noise pick-up. With lithium backup, this circuit is used to build a 1-Wire rain gauge and a hub-mounted wheel odometer. In those appli-

cations, a small permanent magnet moves past the reed switch each time a tipping bucket fills and empties or the wheel rotates one full turn, respectively. This momentarily closes the reed switch, incrementing the counter to indicate 0.01in of rain fall or one revolution. The circuit is also used in a 1-Wire weather station to measure wind speed.

Measuring humidity on the 1-Wire net

Humidity is an important factor in many manufacturing operations and also affects personal comfort. With the proper sensing element, it can be measured over the 1-Wire net. The sensing element specified here develops a linear voltage versus relative humidity (RH) output that is ratiometric to supply voltage. That is, when the supply voltage varies, the sensor output voltage follows in direct proportion. This requires measuring both the voltage across the sensor element and its output voltage. In addition, calculating true RH requires knowing the temperature at the sensing element. Because it contains all the necessary functions for calculating, the DS2438 with its two ADCs and a temperature sensor makes an ideal choice for constructing a humidity sensor. In **Figure 3**, the analog output of the HIH-3610 humidity-sensing element is converted to digital by the main ADC input of a DS2438. The bus master first has U1, the DS2438, report the supply voltage level on its V_{DD} pin, which is also the supply-voltage for U2, the sensing element. Next, the master has U1 read the output voltage of U2 and reports local temperature from its on-chip sensor. Finally, the master calculates true RH from the three parameters supplied by U1.

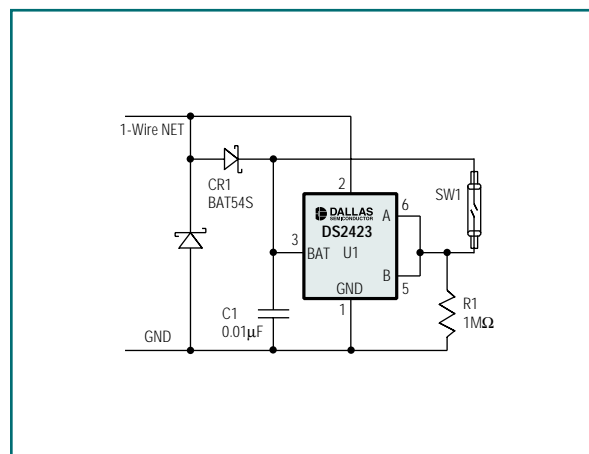

Figure 2. The basic DS2423 counter circuit uses a reed switch as an input.

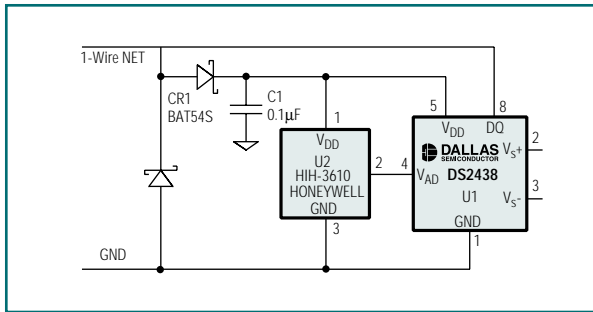

Figure 3. A DS2438 with parasite power is ideal to construct a humidity sensor.

Measuring barometric pressure on the 1-Wire net

Barometric pressure is another important meteorological parameter that can be measured over a 1-Wire net using the DS2438. By selecting a ratiometric pressure sensor that contains comprehensive on-chip signal-conditioning circuitry, the circuit is very straightforward. You must know both the output voltage representing atmospheric pressure and the supply voltage across the element to accurately calculate barometric pressure. Because the MPXA4115 pressure sensor can require as much as 10mA at 5V, an external power source is needed. Note that external power should also be connected to the DS2438's power pin. This allows the DS2438 to measure the supply voltage applied to the pressure-sensing element. Flexible tubing can be routed to sample the outside air pressure and avoid unwanted pressure changes (noise) caused by doors and windows opening and closing or elevators moving inside the building.

Measuring wind direction on the 1-Wire net

The original 1-Wire weather station used DS2401s to label each of the eight magnetic reed switches in its wind direction sensor, as shown in **Figure 4**. A single DS2450 quad ADC can perform the same function with five resistors. As the wind rotates the wind vane, a magnet mounted on a tracking rotor opens and closes one (or two) of the reed switches. When a reed switch closes, it changes the voltages seen at the input pins of U1, the DS2450. For example, if the magnet is in a position to close S1 (north), the voltage seen on pin 7 changes from V_{CC} to $\frac{1}{2}V_{CC}$, or approximately from 5V to 2.5V. Since all 16 wind vane positions produce unique 4-bit signals from the ADC, it is only necessary to indicate north, or specify which direction the wind vane is currently pointing to initialize the sensor.

Because two reed switches are closed when the magnet is midway between them, just eight reed switches indicate 16 compass points. Referring to the schematic and position 2 in Table 1, which lists the voltages seen at the ADC inputs for all 16 cardinal points. Observe that when S1 and S2 are closed 3.3V is applied to ADC inputs B and C. This occurs because the parallel combination of pullup resistors R2 and R3 act as a single resistor half their value connected in series with R1 to form a voltage divider with $0.66V_{CC}$ across R1. Note that this condition occurs twice more at switch positions 4 and 16 generating 3.3V at those cardinal points also.

Table 1. Wind vane position versus the voltage seen at the four DS2450 ADC inputs

CARDINAL POINTS	VOLTAGE INPUT AT D (V)	VOLTAGE INPUT AT C (V)	VOLTAGE INPUT AT B (V)	VOLTAGE INPUT AT A (V)
1	5	2.5	5	5
2	5	3.3	3.3	5
3	5	5	2.5	5
4	5	5	3.3	3.3
5	5	5	5	2.5
6	0	5	5	2.5
7	0	5	5	5
8	0	0	5	5
9	5	0	5	5
10	5	0	0	5
11	5	5	0	5
12	5	5	0	0
13	5	5	5	0
14	2.5	5	5	0
15	2.5	5	5	5
16	3.3	3.3	5	5

Measuring solar radiance on the 1-Wire net

The amount of sunlight and its duration are additional parameters easily measured with 1-Wire sensors. The amount is a measure of air and sky conditions, while duration is related to the equinoxes and the length of the day. Although the mechanical and optical implementations tend to be complex, the electronics can be easily created using a DS2438. **Figure 5** illustrates a solar-radiance sensor built using a sense resistor connected in series with a photodiode. Light striking the photodiode generates photocurrents that develop a voltage across the sense resistor that is read by the ADC. Optical filters can be added to control both the wavelength and optical bandpass to which the sensor responds.

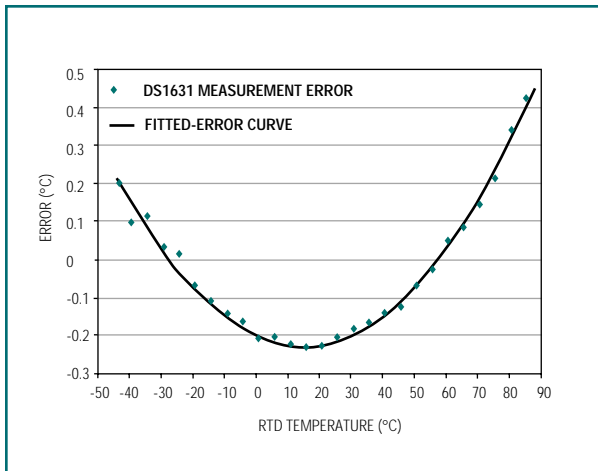

Figure 2. This example of a fitted-error curve relative to DS1631 measurement error illustrates the high level of accuracy required for some scientific and industrial applications.

T_{ZERO_SLOPE} is the temperature at which the error curve has zero slope, and $OFFSET$ is the error at T_{ZERO_SLOPE} . After determining values for α , $OFFSET$, and T_{ZERO_SLOPE} so Equation 1 provides a close fit to the temperature sensor's output-error curve, the user can calculate the approximate measurement error at any temperature and then compensate for the error by subtracting the calculated value from the measured temperature. Thus, the compensated temperature is calculated as:

$$T_{COMP} = T_{TS} - \text{Error} = T_{TS} - [OFFSET + \alpha(T_{TS} - T_{ZERO_SLOPE})^2] \quad (2)$$

Note that it may take several iterations to arrive at values for T_{ZERO_SLOPE} , $OFFSET$, and α that provide the best-fit curve. Once initial estimations for T_{ZERO_SLOPE} and $OFFSET$ have been made, α can be calculated with readily available math or spreadsheet software.

For best results, each temperature sensor should be characterized over the required temperature range to determine the best-fit calculated-error curve for a specific device.

Example

This example uses the DS1631 data from Figure 1 to illustrate the compensation technique described above. From examining Figure 1, T_{ZERO_SLOPE} for this device is estimated at $+15^\circ\text{C}$ and $OFFSET$ at -0.23°C . Plugging these values into Equation 1 and then solving for α gives $\alpha = 1.28 \times 10^{-4}$, which provides a very close fit to the measured error curve as shown in **Figure 2**. The error of the compensated temperature (calculated with Equation 2) relative to the RTD measured temperature is illustrated in **Figure 3**. The compensated error is less than $\pm 0.06^\circ\text{C}$ over the entire -35°C to $+85^\circ\text{C}$ temperature range, whereas without correction, the error was $+0.5^\circ\text{C}/-0.3^\circ\text{C}$ over the entire range. Thus, this compensation technique provides much higher accuracy over the device's characterized temperature range than can be obtained with standard factory calibration. Also, if the DS1631's EEPROM registers are not required for thermostatic operation, this compensation technique can be simplified by storing the compensation coefficients in them.

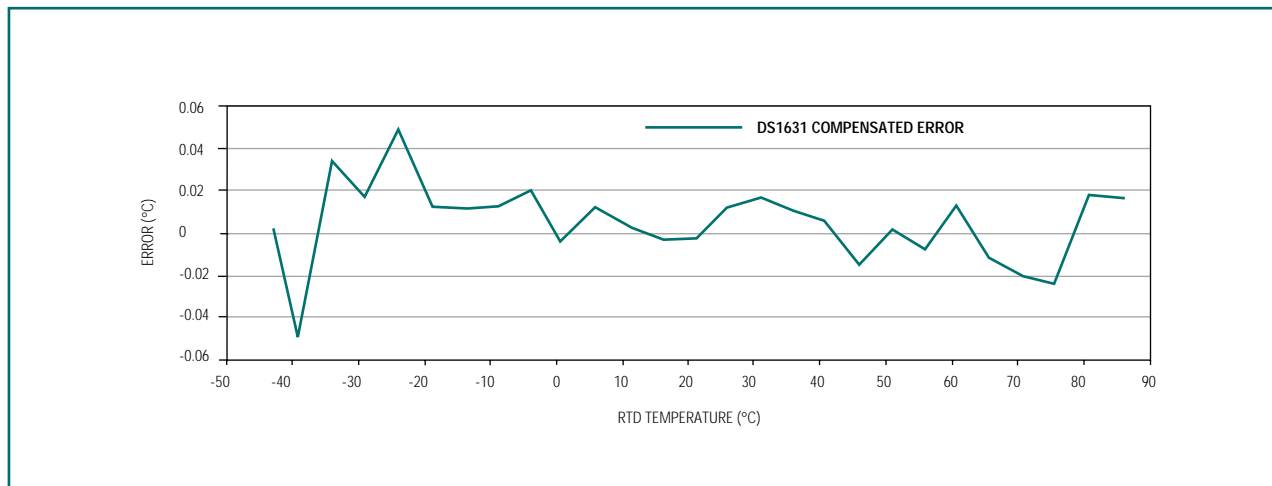

Figure 3. Compensated error provides much higher accuracy over the device's characterized temperature range than standard factory calibration.

DESIGN SHOWCASE

Reducing error in bandgap-based temperature sensors with curve fitting

Direct-to-digital temperature sensor ICs commonly use a bandgap proportional-to-absolute temperature (PTAT) architecture to produce relatively high-accuracy measurements at a reasonable price. Maxim/Dallas Semiconductor uses unique manufacturing methods to provide factory-calibrated bandgap/PTAT-based temperature sensors with accuracy as high as $\pm 0.5^\circ\text{C}$. This level of accuracy is sufficient for many applications, however, some scientific and industrial applications require even greater precision.

An inherent curvature in the bandgap voltage coefficient limits how precisely bandgap-based temperature sensors can be calibrated beyond a narrow temperature range. Fortunately, the nonlinearity of the voltage coefficient has a second-order shape. This makes it simple for the user to improve the accuracy by up to 10x by mathematically compensating for the offset and curvature of the error characteristic. This improvement is achieved by “fitting” a second-order equation to the device error curve, and then using the customized equation to partially eliminate the error at a given temperature. The details of this curve-fitting technique are explained in this article.

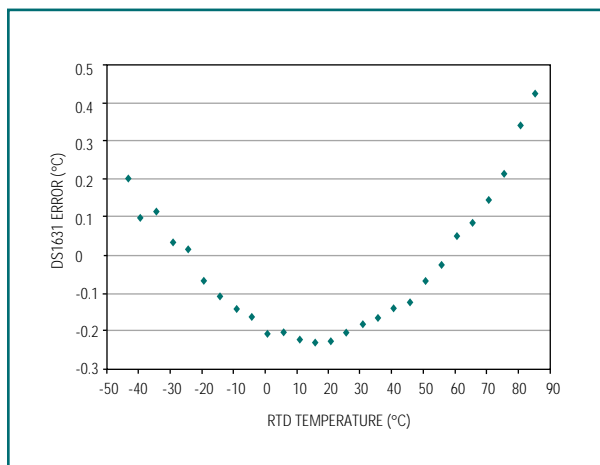

Figure 1. The second-order curvature is clearly visible in the DS1631 example of measurement error vs. RTD measured temperature.

Concept

The PTAT node in bandgap circuits has a voltage coefficient that increases monotonically with increasing temperature and is highly stable over time and environmental stresses. These characteristics make the bandgap PTAT node an excellent temperature-measurement device that provides high accuracy under the appropriate calibration conditions.

Although the PTAT characteristic is approximately linear, it has a slight second-order curvature, which translates to a second-order error relative to the ambient temperature. To illustrate this point, a DS1631 IC was used to measure the temperature in a thermally conductive liquid bath at 5°C intervals over a -3°C to $+85^\circ\text{C}$ temperature range. The temperature of the liquid was simultaneously measured by a NIST traceable platinum RTD to provide a very accurate temperature reading for the liquid during each DS1631 measurement. **Figure 1** shows a plot of the DS1631 measurement error relative to the RTD measurements. In this figure, the second-order curvature is clearly visible. Notice that this plot has a negative offset at the center of the curve. This offset was intentionally introduced during calibration so the accuracy at the central temperature was reduced, but the overall accuracy was higher over a wider temperature range.

The error-correction method presented in the following section compensates for both the curvature and offset of the output characteristic of bandgap-based temperature sensors.

Implementation

The second-order error characteristic of bandgap-based temperature sensors (like the one shown in Figure 1) is represented by the following equation:

$$\text{Error} = \text{OFFSET} + \alpha(T_{\text{TS}} - T_{\text{ZERO_SLOPE}})^2 \quad (1)$$

where T_{TS} is the temperature measured by the temperature sensor, α is a curvature correction coefficient,

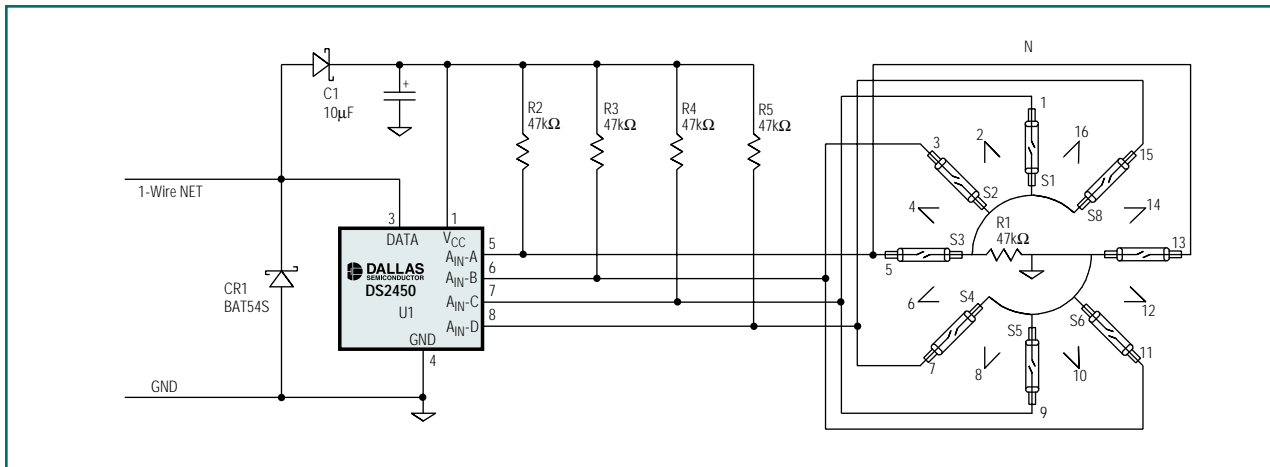

Figure 4. A DS2450 quad ADC-based wind-direction sensor measures 16 compass points.

Measuring a thermocouple on the 1-Wire net

One can also measure extreme temperatures using conventional thermocouples (TC) that are directly digitized at the cold junction using a DS2760 multifunction 1-Wire chip. The twisted-pair cable of the 1-Wire net covers the distance between the TC and bus master, effectively replacing the expensive TC extension cable normally used. Because of its unique ID address, multiple smart TCs can be arbitrarily placed where needed along the net, greatly minimizing the positioning and cost of an installation. With an LSB of 15.625µV, the chip can directly digitize the millivolt-level output produced between the hot and cold junctions of the typical TC as its on-chip temperature sensor continuously monitors the temperature at the cold junction of the TC. It contains user-accessible memory for storage of sensor-specific data such as TC type, location, and the date it was placed into service. This information minimizes the probability of error due to the mislabeling of sensors. Thus, a DS2760 can be used with any TC type because the bus master's calculations are based on the

stored data and the temperature of the cold junction, as reported by the on-chip temperature sensor. **Figure 6** illustrates both the simplicity and ease with which a DS2760 can be used to convert a standard thermocouple into a smart sensor with multidrop capability. Adding R1 allows V_{DD} to be measured, which is useful in troubleshooting to verify that the voltage available on the 1-Wire net is within acceptable limits.

Summary

1-Wire technology made possible the combination of electronic communication and instrumentation based on positive identification of individual nodes on a single self-powered net. Continued development of the technology has increased the array of 1-Wire chips able to interface with the environment, measuring events, voltage, current, temperature, position, etc. In turn, these chips enabled the construction of sensors that measure a host of environmental parameters on a single twisted-pair cable as described within this article.

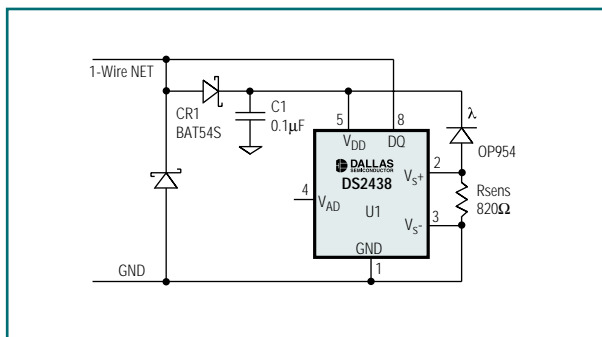

Figure 5. The amount of sunlight available can be easily measured with a photodiode and a DS2438.

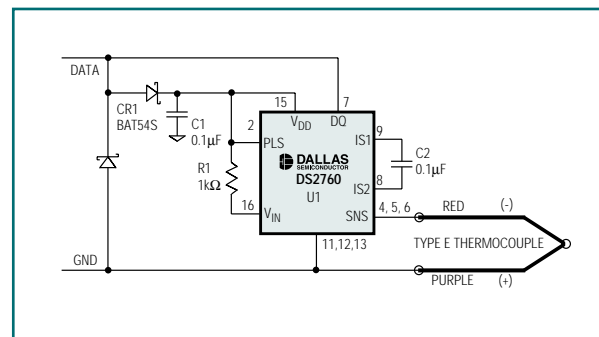

Figure 6. A DS2760 can convert a conventional TC into a smart sensor with multidrop capability.

Including ROM, EPROM, and EEPROM in 1-Wire slaves in a stainless-steel case called an iButton further enabled a personal electronic authentication. Personal and data security advanced with the creation of SHA-1-based 1-Wire chips in iButtons for use with monetary transactions. Whether housed in an armored stainless-steel iButton or standard IC packages, 1-Wire communi-

cation uses a noncritical two-contact interface. 1-Wire technology is now used for transportation tokens, identification badges, entry security, and after-market control. New applications are continually being added. Visit www.ibutton.com/solutions to learn more about commercial ventures using 1-Wire technology.

is a 12 x 1 matrix with 75Ω impedance matching and is designed for single-ended signals. The DS21Q55 can operate in both T1 and E1 modes with a variety of termination configurations: 75Ω/100Ω/120Ω. With so many configurations, checking if the device will meet pulse mask in all possible applications for every port quickly becomes difficult. The two matrix cards make this much easier by allowing the user to isolate signals on a certain port through a specified path. For example, in T1 mode a differential signal of 100Ω is required and the device must meet the template up to 655ft. By using the DSMAT110X8 card and the line simulator, the pulse mask can be measured for all possible LBOs. However, in E1 mode a differential signal of 120Ω or a single-ended signal of 75Ω may be selected depending on the application. Therefore, the appropriate matrix must be used to prevent shorting one of the differential signals from the E1 twisted-pair cable. Pulse-mask testing for E1 is done at

oft only so the line simulator is set for pass-through mode. It simply depends on how the device is configured.

The lower block in Figure 6 shows another multiport device, the DS3154. This device is similar to the DS21Q55 as it can switch between two different transmission modes, which in this case are T3 and E3. The specs for T3 and E3 call for 75Ω termination so only the DSMAT75X12 card is necessary. But again, for T3 mode the device must meet template for the entire LBO, so a line simulator is necessary. For E3 mode the line simulator is set in pass-through mode.

As the port counts increase on the data transmission equipment, so does the need for testing the transmission signal for pulse-mask compliance quickly and reliably.

Dallas Semiconductor/Maxim developed solutions to satisfy this need for both T1/E1 and T3/E3 applications.

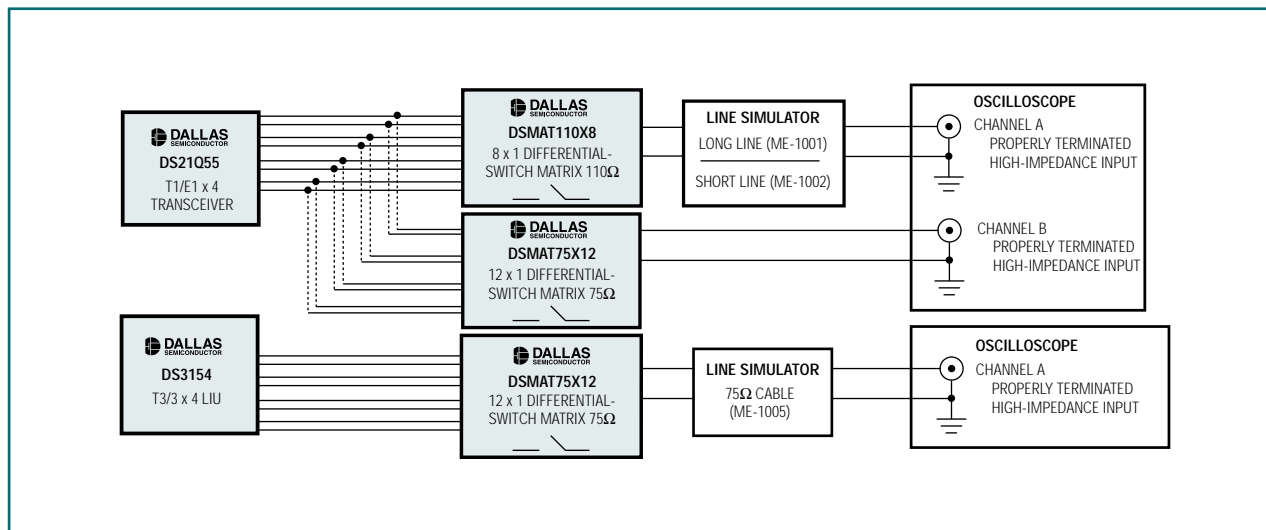

Figure 6. With T1 and T3 networks, a line simulator is usually added to provide the proper capacitive loading on the transmission line.

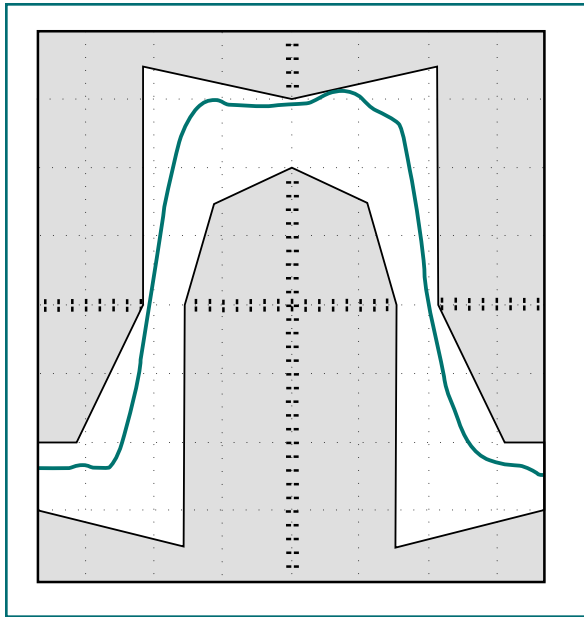

Figure 4. E3 pulse (34.368Mbps) signals are measured at the source

the number of zeros before transmitting a one. E1 and E3 signals require that all pulses meet the specified template so there is not a spec for an isolated pulse.

The transmission line is then loaded with the appropriate resistor value and connected to an oscilloscope for measurement. **Figure 5** shows two common termination schemes. The upper drawing diagrams the proper way to terminate the differential transmission line. The scope must be set to receive a differential signal for this to function properly. T1 networks require a $100\Omega \pm 5\%$ resistive termination as the load; therefore, $50\Omega \pm 5\%$ resistors are used on TTIP and TRING. For E1, which is 120Ω termination, two $60\Omega \pm 5\%$ resistors are used.

Viewing the pulse mask of a transmission signal while concurrently using the remaining channels of the oscilloscope for other purposes is often recommended. This requires use of an active differential probe—several are on the market. Use one that has the desired impedance termination and is rated for the oscilloscope being used. Tektronix, LeCroy, and HP all make differential probes with termination that can be used with T1 or E1 transmission signals.

The lower termination scheme in Figure 5 is for single-ended transmission lines. To measure this pulse mask, simply add the termination resistor as close as possible to the high-impedance input of the oscilloscope. This will

minimize the reflections and noise detected by the oscilloscope when making the pulse-mask measurement.

When different LBOs are required, as with T1 and T3 networks, a line simulator is usually added to provide proper capacitive loading on the transmission line (**Figure 6**).

Problems with testing pulse masks

A problem can develop with multiport transmission devices. While there are a number of multichannel oscilloscopes on the market that can measure multiple pulses at once, many of the line simulators are single-port only. An $N \times 1$ switch matrix is required to fully utilize both the line simulator and the oscilloscope without constantly moving cables for measurement. Maxim/Dallas Semiconductor developed two matrix cards that solve this problem and provide a GPIB interface for communicating to the board remotely. Both matrix boards are designed to be impedance controlled to reduce reflections in the measured signal. Also, each matrix board has a separate transmit and receive path for each signal path. This is useful when testing for receiver sensitivity.

Figure 6 represents a multiport T1/E1 single-chip transceiver (the DS21Q55) and a T3/E3 line-interface unit (the DS3154) with the associated hardware required for making a pulse-mask measurement.

In the upper block, notice the DSMAT110X8 between the DS21Q55 and the line simulator as well as the DSMAT75X12 between the DS21Q55 and the oscilloscope. The DSMAT110X8 is an 8×1 matrix card specifically designed for differential telecom signals that require 100Ω to 120Ω impedance matching. The DSMAT75X12

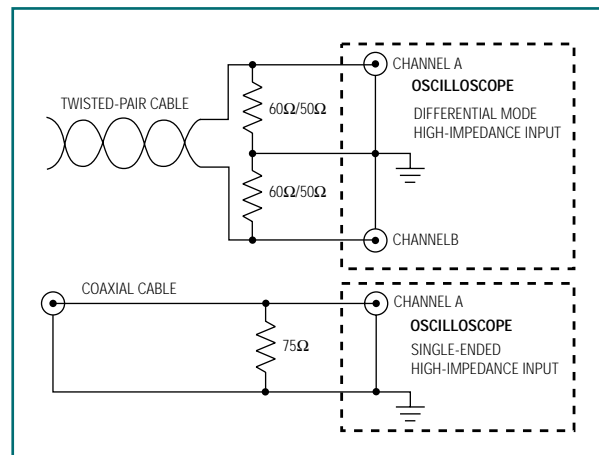

Figure 5. The upper drawing illustrates the proper way to terminate the differential transmission line, while the lower one is a termination example for single-ended transmission lines.

Telecom template measurement and compliance

In the telecommunication industry, it is often necessary to design equipment that interfaces with older and existing telecommunication systems. To ensure that a piece of equipment functions properly in a legacy system, several application-dependent specs are defined for manufacturers to follow. These specs pertain to data transfer, signal timing requirements, and functions that must be executed when data-transfer errors are detected. One group of specs particularly important to manufacturers of data transmission equipment concerns transmission-signal quality. Depending on the type of system, there is a spec for how the transmission signal should appear. The measured signal should fit within a predefined template called a pulse mask. This article examines the specifications for T1, T3, E1, and E3 pulse masks and testing transmission signals for pulse-mask compliance. It also discusses some of the problems that can occur when testing multiport transmission devices. Maxim/Dallas Semiconductor has a line of multiport transceivers for both T1/E1 systems and T3/E3 systems, as well as support hardware to make testing the pulse mask for multiport devices easier. Interface and pulse-mask specifications for T1/E1/T3/E3 networks follow. The specifications for the digital networks were taken from the International Telecommunication Union (ITU) document G.703, October 1998, and the American National Standard for Telecommunications (ANSI) document ANSI T1.102-1993.

T1 pulse-mask template

The first and most common digital transmission system in North America is a T1 network (1.544Mbps). This system of transmitting digital data was developed in the mid 1960s for public telephone providers. Since then, T1 networks changed their function from transmitting strictly digital voice conversations to large data packets that are the core transmission technology for applications such as wide area networks (WAN) and the Internet.

For each T1 line, the physical connection that a customer sees is always two twisted-pair lines: one for the transmit data and one for the receive data. Both are differential pairs that are terminated with a 100Ω resistive load. To measure the pulse mask, the transmit-data path is selected and measured at the end of the transmission line. Many T1 transceivers provide options to compensate for the resistive and capacitive loading of the transmission line by adjusting the amplitude of the T1 pulse. Dallas Semiconductor/Maxim has T1 transceivers that can be configured for both short-haul (DSX-1) lines, which can be up to 655ft with 22 AWG cable, and long-haul (CSU) lines, which are rated to a maximum of -36dB of signal loss. This is normally referred to as the line build-out (LBO) of the transmission line. Within the short-haul (DSX-1) lines and long-haul (CSU) lines, Dallas Semiconductor/Maxim T1 transceivers can be set for the proper LBO. T1 interface specifications for a pulse mask are found in **Table 1**.

Regardless of how the T1 device is configured, the T1 signal must fit within the pulse mask at the end of the line when transmitting an isolated pulse. An isolated pulse is normally a positive pulse that is both preceded and followed by a certain number of zeros. The number of zeros required is determined by the spec ANSI T1.102-1993.

Table 1. T1 interface specification for pulse mask

INTERFACE PARAMETERS	SPECIFICATIONS
Nominal line rate	1.544Mbps
Medium	One balanced twisted pair is used for each direction of transmission.
Isolated pulse	A positive pulse that is preceded by four zeros and followed by one or more zeros.
Test-load impedance	A resistive test load of 100Ω ±5%.
Pulse amplitude	The pulse amplitude for a positive isolated pulse is between 2.4V and 3.6V.
Pulse shape	The shape of every pulse that approximates an isolated pulse conforms to the mask in Figure 1. This shape is shown in a normalized form, with the nominal pulse amplitude shown as 1.0.

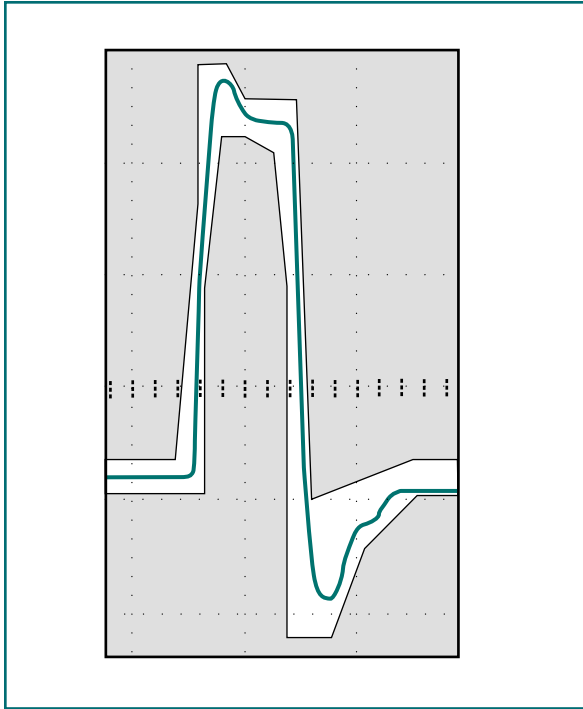

Figure 1. T1 pulse amplitude (1.544Mbps) is measured in the center of the pulse located at time T0.

T1 pulse masks are normalized when displayed in graphical form with the nominal pulse amplitude of 1.0 inside the mask. The pulse amplitude is measured in the center of the pulse located at time T0 in **Figure 1**. If the amplitude at T0 is within 2.4V and 3.6V, the signal is scaled linearly to determine if it fits the pulse mask.

E1 pulse-mask template

There are other digital transmission systems besides T1 networks. One common system used widely in Europe and Asia is E1 (2.048Mbps). From a broad overview, E1

networks are similar to the T1 networks with some minor differences in the line rate and number of channels per frame. E1 networks still require two connectors (one used to transmit data, the other to receive data) and a resistive termination at the end of the line; the signals require that pulses meet a specified template. However, the spec for E1 requires that all the pulses meet the template and not just an isolated pulse (**Figure 2**). E1 is tested at 0ft, or at the source of the E1 pulse, while T1 pulses must meet the template for the entire line length. Two types of cables are used in E1 mode: 75Ω coaxial cable and a 120Ω twisted-pair cable. Both cables have different associated nominal amplitudes. For the 75Ω coaxial cable, the amplitude must be 2.37V ±10% at T0. For the 120Ω twisted-pair cable, the amplitude must be 3.0V ±10%. This pulse must fit within this template and cannot be scaled. **Table 2** shows E1 interface specifications for a pulse mask.

T3 and E3 pulse-mask template

When higher data rates are needed, T3 and E3 lines are often used. A T3 line (44.736Mbps) handles up to 28 T1 lines or 21 E1 lines; an E3 line (34.368Mbps) can hold up to 16 E1 lines. As with T1 and E1 networks, the T3 and E3 pulses must also meet a specified template. See **Figures 3** and **4** for a graphical representation of each template. Both the T3 and E3 pulses are terminated with 75Ω resistive loads. T3 pulses must meet the template for the entire line length, which can be up to 450ft. E3 signals are measured at the source. T3 and E3 interface specifications for pulse masks are shown in **Tables 3** and **4**, respectively.

Pulse-mask testing

Testing the pulse mask of a transmission device is a standard practice for not only the manufacturer, but also for the end users of telecommunications equipment. To

Table 2. E1 interface specification for pulse mask

INTERFACE PARAMETERS	SINGLE ENDED	DIFFERENTIAL PAIR
Nominal line rate	2.048Mbps	2.048Mbps
Medium	One coaxial pair is used for each direction of transmission.	One balanced twisted-pair cable is used for each direction of transmission.
Test-load impedance	A resistive test load of 75Ω ±5%.	A resistive test load of 120Ω ±5%.
Pulse amplitude	The nominal pulse amplitude for a positive isolated pulse is 2.37V.	The nominal pulse amplitude for a positive isolated pulse is 3.0V.
Pulse shape	Every pulse conforms to the mask in Figure 2.	Every pulse conforms to the mask in Figure 2.

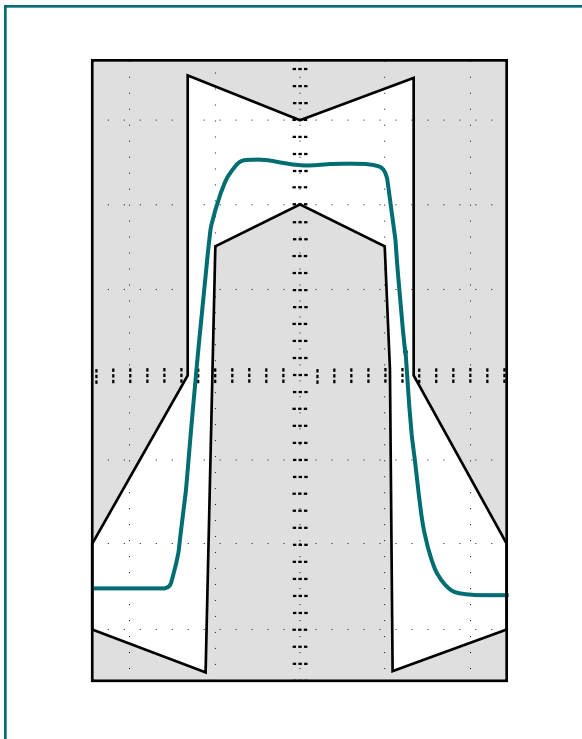

Figure 2. Every E1 pulse (2.048Mbps) must conform to the shape of the template and not just an isolated pulse.

Table 3. T3 interface specification for pulse mask

INTERFACE PARAMETERS	SPECIFICATIONS
Nominal line rate	44.736Mbps
Medium	One coaxial pair is used for direction of transmission.
Isolated pulse	A positive pulse that is preceded by two zeros and followed by one or more zeros.
Test-load impedance	A resistive test load of $75\Omega \pm 5\%$.
Pulse amplitude	The pulse amplitude for a positive isolated pulse is between 0.36V and 0.85V.
Pulse shape	The shape of every pulse that approximates an isolated pulse conforms to the mask in Figure 3. This shape is shown in a normalized form, with the nominal pulse amplitude shown as 1.0.

Table 4. E3 interface specification for pulse mask

INTERFACE PARAMETERS	SPECIFICATIONS
Nominal line rate	34.368 Mbps
Medium	One coaxial pair is used for each direction of transmission.
Test-load impedance	A resistive test load of $75\Omega \pm 5\%$.
Pulse amplitude	The nominal pulse amplitude for a positive isolated pulse is 1.0V.
Pulse shape	The shape of every pulse that approximates an isolated pulse conforms to the mask in Figure 4.

perform this test, place the device in a mode where it is constantly transmitting a known data pattern. T1 and T3 networks have a spec to ensure that an isolated pulse is produced. For T1 signals, an isolated pulse is one preceded by four zeros and followed by one or more zeros. An isolated pulse for T3 signals is a pulse that is preceded by two zeros and followed by one or more zeros. To reduce the reflections during the measurement of the pulse mask, it is highly recommended to maximize

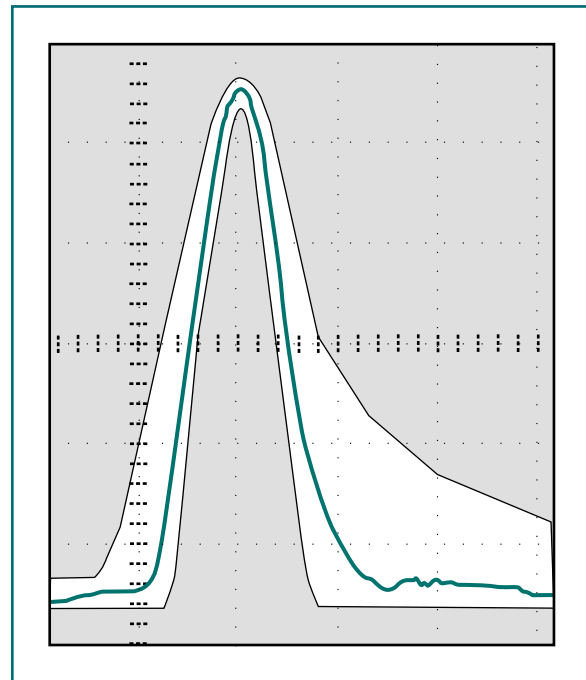

Figure 3. T3 pulses (44.736Mbps) must meet the template for the entire line length.